



## PERFORMANCE DATA SHEET

Meets or exceeds MEPS (Minimum Efficiency Performance Standards), as described by the US Department of Energy in docket 10CFR431 and Natural Resources Canada's Amendment 14

Catalogue #: MTR-122FDJH

HP	kW	Voltage	Frequency	EFF.	P.F.	Frame	Design	F.L. RPM
0,5	0,37	115 / 208 - 230	60Hz	71,3%	0,910	56J	B	3520

FLA			Service Factor	N.L. Amps @ 115V	N.L. Amps @ 230V	KVA Code	L.R. Amps @ 15v	L.R. Amps @ 230v
115	208	230		1,15	2,53		1,264	L
5,03	2,78	2,52						

Start Cap.	Run Cap.	Main Winding $\Omega$ 115V @ 25°C	Main Winding $\Omega$ 230V @ 25°C	Auxillary Winding $\Omega$ @ 25°C	Safe Cold Start (Secs)
100 $\mu$ f/300vac	30 $\mu$ f/450vac	0,7600	3,050	3,280	12

Wgt. Lbs	PH	Duty	Insul. Class	Amb.	Elevation	Temp. Rise° C
25	1	Cont.	F	40°C	1000M (3,300 Ft)	32

% Efficiency		Power Factor		Torque		Protection
Full Load:	71,3%	Full Load:	0,91	Full Load Ft/Lbs	0,7	
3/4 Load:	66,4%	3/4 Load:	0,88	Locked Rotor %	393	
1/2 Load:	49,1%	1/2 Load:	0,86	Break Down %	343	

Rotor Inertia Wk2 Lb-Ft2	Max Load Inertia Wk2 Lb-Ft2	Shaft Material	Frame Material	DE Bracket Type	ODE Bracket Type	Enclosure	NEMA Rating	Lead Wire Size
/	/	304SS	Rolled Steel	Aluminium Alloy		TEFC	IP55	/

Ball Bearings		Grease	Mount Type	Orientation	Paint	Sound Pressure @ 3FT	Sound Power
DE	ODE						
6205	6203	Sealed Bearings	Rigid	Horizontal	Black	68	/

### WIRING CONNECTION DIAGRAM : B

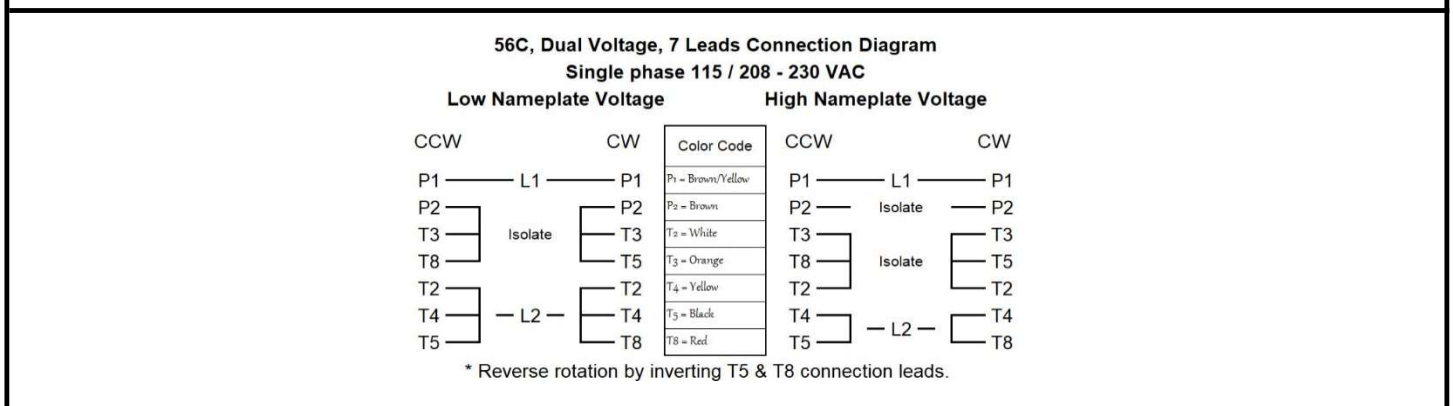



Date: 2023-12-22  
 Customer: \_\_\_\_\_  
 Contact: \_\_\_\_\_  
 Submittee: J.C. Lavallée

Catalogue #: **MTR-122FDJH**

**Meets or exceeds MEPS (Minimum Efficiency Performance Standards), as described by the US Department of Energy in docket 10CFR431 and Natural Resources Canada's Amendment 14**

HP	VAC	RPM	Enclosure	Frame	Frequency	Design	Poles	LR Code Letter	Insulation Class	Temp. Rise °C
0,5	230	3520	TEFC	56J	60	B	2	L	F	32

	0%	25%	50%	75%	100%	125%	150%
Load %	0%	25%	50%	75%	100%	125%	150%
Amps	1,79	1,92	2,04	2,22	2,52	3,15	3,78
Torq ft/lbs	0	0,18	0,37	0,56	0,75	0,94	1,13
RPM	0	3580	3560	3540	3520	3500	3480
Eff	0	26,46	45,99	62,14	71,30	69,33	67,35
PF	0,00	80,00	86,27	88,27	91,00	92,82	95,55

	Locked Rotor	Pull-Up	Breakdown	Rated Load	Idle	Duty	S. F.	Ambient	Elevation	dBa @ 1M
Speed (RPM)	0	1800	2880	3520	3600	Continuous	1,15	40°C	3,300 ft	68
Current (Amps)	21	17,9	12,5	2,52	1,7892	VFD Rating: Meets MG1 parts 31.4.4.2				
Torque (ft-lbs)	2,93	2,49	2,56	0,75	0,0	C.T.	3,05	V.T.	3,28	

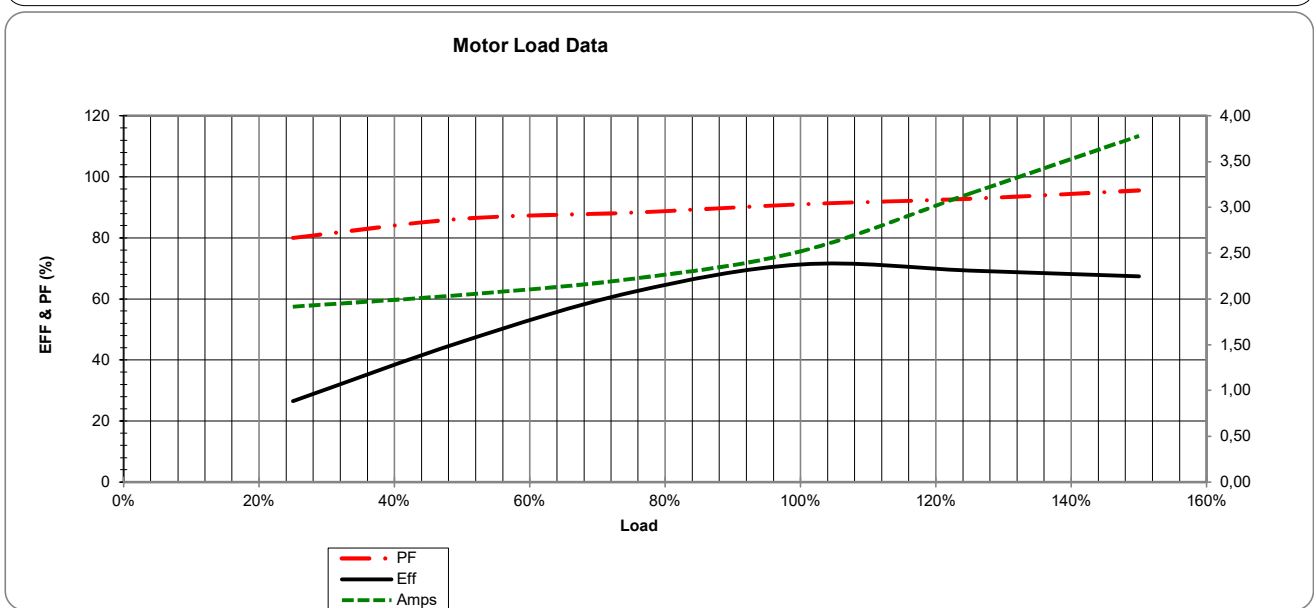
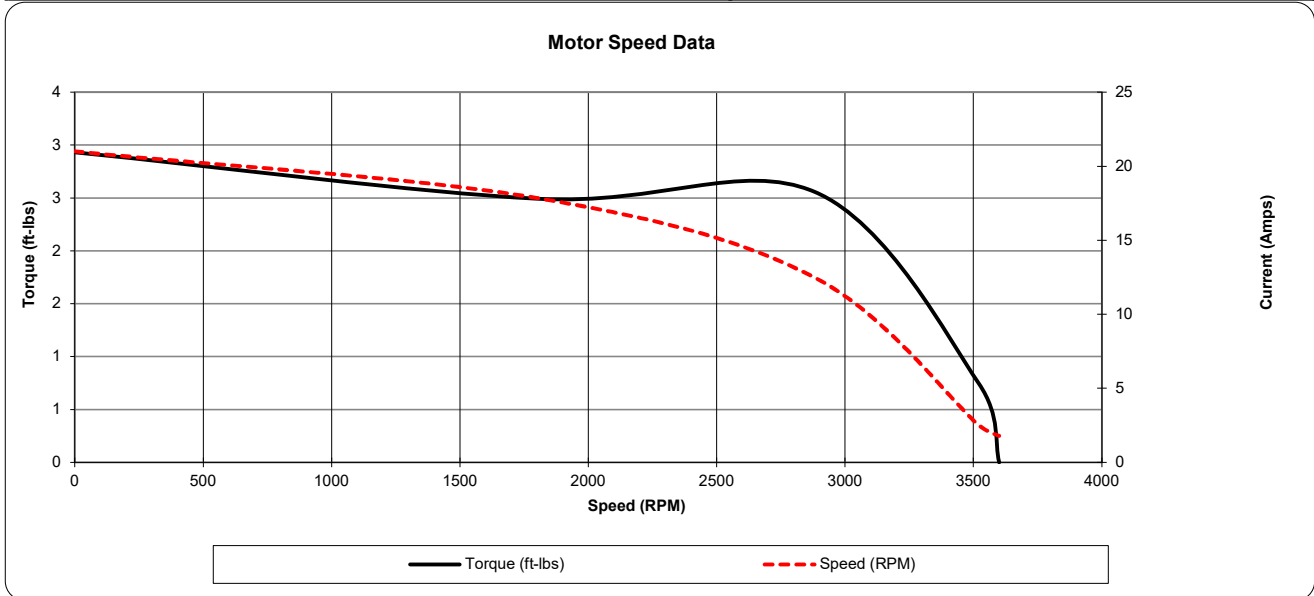

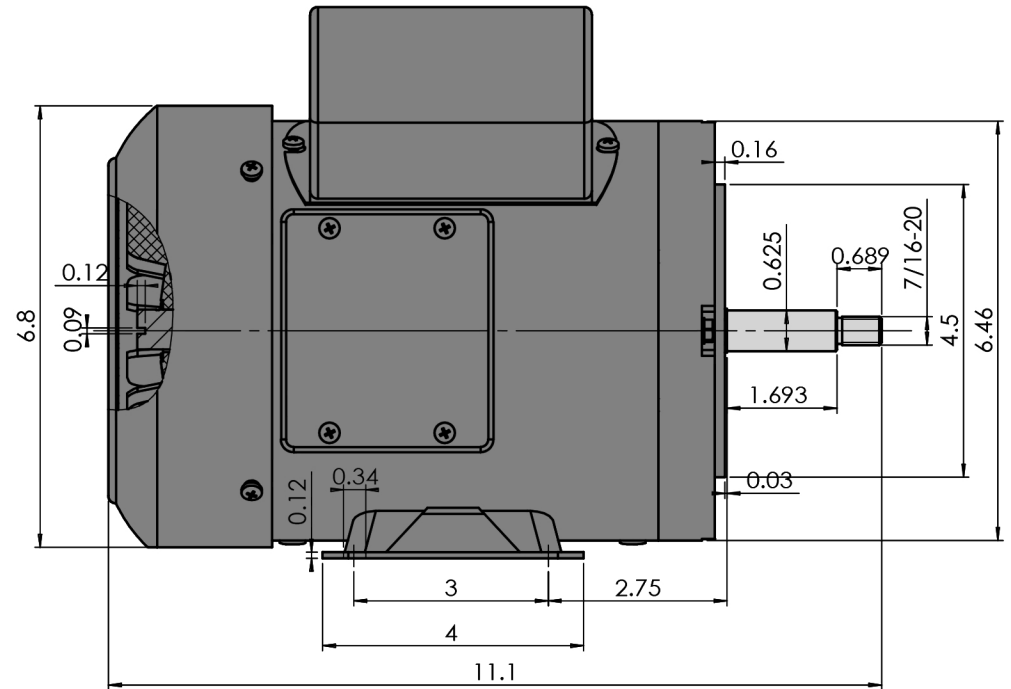
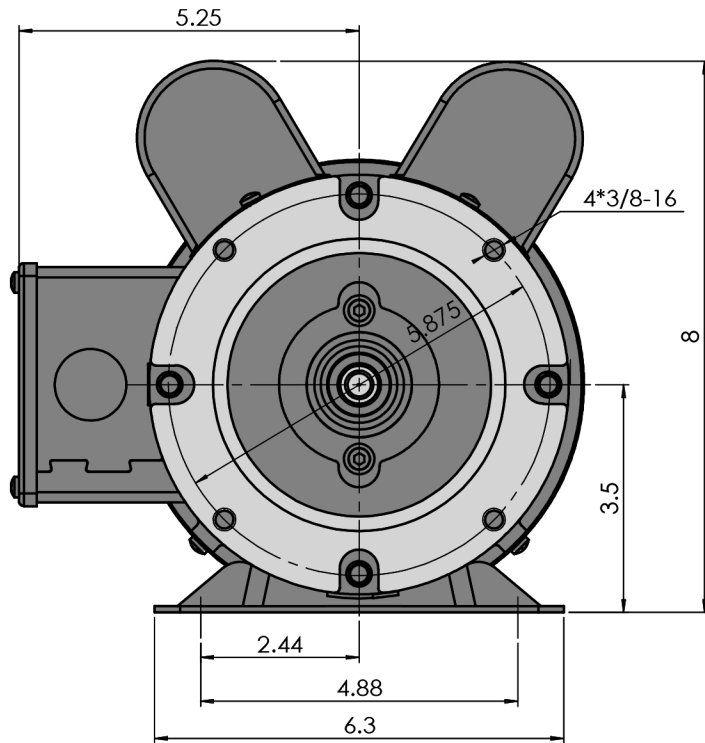

## MTR-122FDJH

Version:1HUA	Revised: November 2022	HP	RPM	FRAME	ENCLOSURE
Customer is responsible in determining that MaxMotion product will fit/perform suitably in the intended application		1/2	3600	56J	TEFC

# SINGLE PHASE CENTRIFUGAL JET PUMP AC MOTORS

HEAVY GAUGE ROLLED STEEL CONSTRUCTION  
TEFC TOTALLY ENCLOSED FAN COOLED

MaxMotion

## Applications:

A versatile design with removable base for footless mounting, for use on jet pumps, Robust motor design to meet demanding high starting torque applications in severe environmental conditions.

## Features:

**Design** - L, suitable for ambient temperature of 40°C, altitude 1000M

**Agency Listings and Standard** - NEMA, CSAus and CSA Certified, RoHS Compliant

**Service Factor** - 1.15

**Electrical Supply** - 115/230VAC, 60Hz

**Mounting** - Universal mounting by feet or C flange, vertical shaft up or down.

**Frame** - NEMA 56C with threaded shaft for fixed CW rotation

**Shaft** - Made of 304 stainless steel with both DE & ODE oil seals

**Windings** - VPI with additional dip and bake, with numbered and color coded wire leads.

**Insulation** - Class F insulation with B temperature rise.

**Protection** - Automatic thermal overload.

**Voltage and Frequency Variation** -  $\pm 10\%$

**Bearings** - Permanently Lubricated High quality Double Shielded Ball Bearings with oversized DE bearings. Lithium based grease operating temperature range – 25° trough 175°C.

**Earthing Terminals** - Grounding screw in conduit box

**Enclosure Protection** - IP55

**Frame Construction** - Rolled Steel with cast aluminum end shields

**Conduit Box** - Rotatable 180°, with ½ NPT knockouts positioned for wiring access every 90° with rubber gasket between box and motor frame.

**Nameplate** - Stainless Steel with etched details.

**Drain Hole** - Positioned in the stator frame at the lowest point, when motors a horizontally mounted.

**Fan Cover** - Plastic fan & heavy duty plastic fan guard

**Warranty** - 1 year



# SINGLE PHASE CENTRIFUGAL JET PUMP AC MOTORS

HEAVY GAUGE ROLLED STEEL CONSTRUCTION

TEFC TOTALLY ENCLOSED FAN COOLED



HP	FL RPM	VOLTS	FRAME	CAT NO.	CONSTRUCTION	NOM EFF.	F.L. AMPS	CODE	WT (Lbs)	DE BRG	ODE BRG	LRT	"C" Dimension (Inch)
0.33	3520	115/230	56J	MTR-132FDJH	Rolled Steel	67,3	3.83/1.92	L	22	6205	6203	300% +	11.1
	1770	115/230	56J	MTR-134FDJH	Rolled Steel	68,8	3.92/1.96	M	26	6205	6203	300% +	11.1
0.50	3520	115/230	56J	MTR-122FDJH	Rolled Steel	71,3	5.03/2.52	L	25	6205	6203	300% +	11.1
	1765	115/230	56J	MTR-124FDJH	Rolled Steel	74,6	5.7/2.85	M	27	6205	6203	300% +	11.1
0.75	3520	115/230	56J	MTR-342FDJH	Rolled Steel	77,5	6.82/3.41	L	26	6203	6203	300% +	11.1
	1760	115/230	56J	MTR-344FDJH	Rolled Steel	77	7.33/3.66	L	31	6205	6203	300% +	11.9
1	3520	115/230	56J	MTR-102FDJH	Rolled Steel	77,9	8.61/4.31	J	30	6205	6203	300% +	11.9
	1760	115/230	56J	MTR-104FDJH	Rolled Steel	79,8	9.09/4.54	K	38	6205	6203	300% +	12.9
1.5	3520	115/230	56J	MTR-152FDJH	Rolled Steel	82,3	12.47/6.23	J	36	6205	6203	283%	12.9
	1750	115/230	56J	MTR-154FDJH	Rolled Steel	81,8	12.41/6.2	J	44	6205	6203	294%	12.9
2	3510	115/230	56J	MTR-202FDJH	Rolled Steel	83	15.92/7.96	H	42	6205	6203	273%	12.9
	1750	115/230	56J	MTR-204FDJH	Rolled Steel	84,7	16.17/8.08	H	50	6205	6203	269%	14.1